

## CONVERSION KIT

Emergency kit for LED lamp fitting

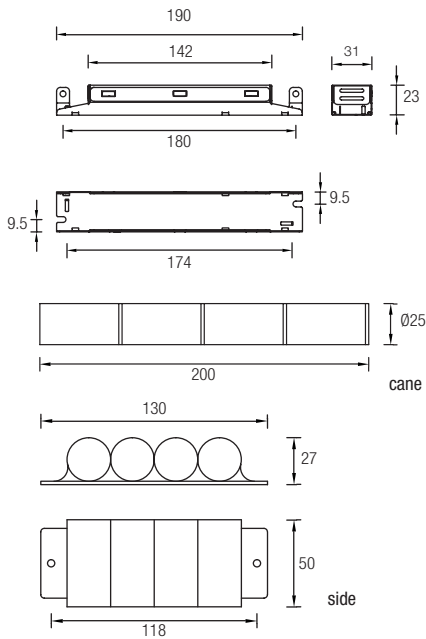

Dimension: mm NTS

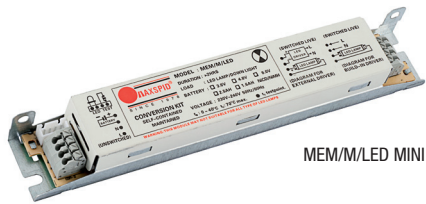
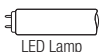
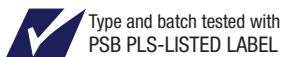

### TECHNICAL DATA

Mode of operation	: Maintained
Lamp	: LED Lamp
Rated duration	: 2 hr and others
Mains supply	: 230 Volts, 50/60Hz
Power consumption	: < 3VA
Battery	: High temp nickel cadmium
Charge monitor	: Green LED Ø5mm
Test facility	: Push-off test switch
Safety feature	: Low volt cut-off preventing battery overdischarge
Fitting construction	: Electro galvanised steel with epoxy powder coating
Weight (module only)	: 0.15kg (gross)
Compliance	: IEC 61347-2-7, IEC 61347-1
Warranty	: 1 year

### ORDERING GUIDE

(Please check with Sales Dept if customisation is required)

Model	Lamp (length)
MEM/M/LED MINI	2ft to 5ft T5/T8 LED Lamp

\*\* Please ensure that your LED Driver is suitable for Emergency installation.